

TECHNOLOGY MEETS QUALITY

Takeuchi proactively responds to our customers' needs through world class product design, research and development, manufacturing and after the sale product support.

Welcome to the next generation of Takeuchi Excavators.



Boom Swing
for digging side ditches



Dozer Blade
for ground levelling



Rubber Tracks
for comfortable operating

PRINCIPLE FEATURES of the TB1140

OPERATING RANGE : mm

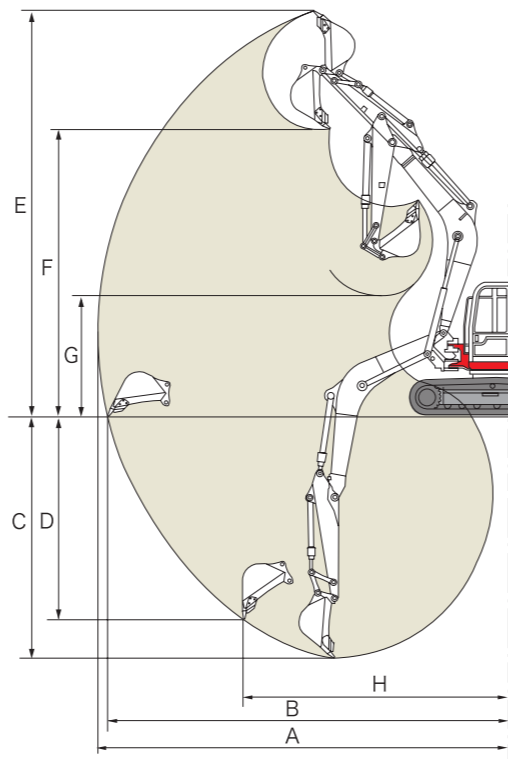

DIMENSION : mm

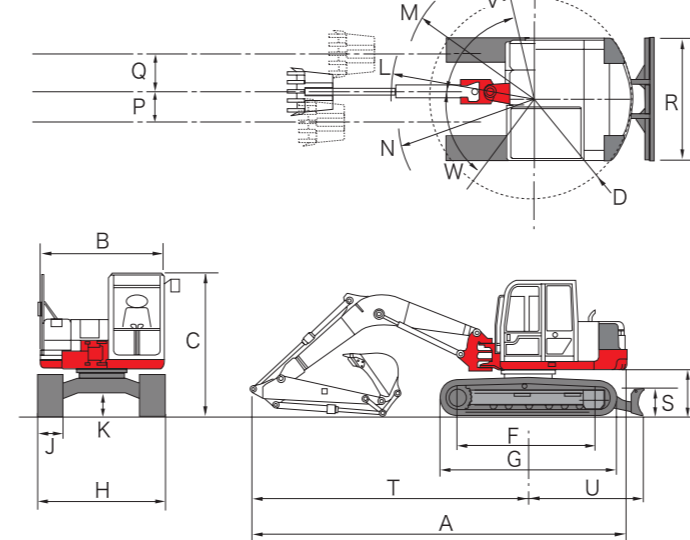

Note: All units in mm

Item	Standard Arm		Long Arm		A	N
Crawlers	Rubber	Steel	Rubber	Steel	7725	2665
A Max. Digging Radius	8280	-	8755	-	B 2490	P 625
B Max. Floor Digging Radius	8080	-	8570	-	C 2785	Q 760
C Max. Digging Depth	4990	5000	5490	5500	D 2000	R 2490
D Max. Vertical Digging Depth	4145	4150	4630	4635	E 920	S 550
E Max. Digging Height	8305	8300	8665	8660	F 2890	T 5725
F Max. Dumping Height	5855	5850	6215	6210	G 3590	U 2340
G Min. Dumping Height	2335	2330	1850	1845	H 2490	V 77°
H Max. Vertical Digging Radius	5240	-	5355	-	J 500	W 53°
J Max. Raising Height	510	500	510	500	K 450	
K Max. Lowering Depth	490	500	490	500	L 2855	
					M 2255	

Specifications

(Cab, Steel Tracked, Standard Arm, Breaker Piping Standard, Fops Cabin) (Option: Rubber Tracked)

Weight	Machine Weight (kg)	14,230	Rear Slew Radius	2000	Track Width ST	500
Bucket	Bucket Capacity (m ³)	0.34(Struck)/0.45(Heaped)	Min. Ground Clearance	450	Operating Range: (mm)	
Bucket Width (mm)	970		Performance		Max. Dig Depth	4990
Diesel Engine (Water-cooled)	Model	ISUZU BB-4BG1TRE	Traction Speed (km/h)	3.0/5.3	Max. Vertical Dig Depth	4145
Type	4CYL-4CYCL		Upper Slew Speed (rpm)	13.8	Max. Dump Height	5855
Rated Output (kW)	62.2/2050rpm		Gradeability (deg)	35°	Max. Dig Height	8305
Max. Torque (Nm)	304		Max Dig Power bucket (kN)	98.7	Max. Dig Radius	8280
Displacement (cc)	4329		Max Dig Power Arm (kN)	64.9	Max. Floor Dig Radius	8080
Cool Water Capacity (l)	21		Ground Press (kPa)	41.7	Min. Slew Radius	2255
Lub. Oil Capacity (l)	15.8(max)		Dozer Blade (mm)		Max. Bucket Offset RH/LH	760/625
Fuel Tank Capacity (l)	233		Width x Height	550x2490	Hydraulic System	
Overall Dimension (mm)			Operating Range up/down	510/490	Pump Type	Variable(P1+P2)+Gear(P3+P4)
Length (in transport)	7725		Off-set Dig Function		Set Press (Mpa)	34.3x2+23.6+3.9
Width	2490		Type	Boom Swing	Discharge (l/min)	106.6x2+51.9+20.5
Height	2785		Swing Angle RH/LH	53°/77°	Breaker & Service Port (l/min)	106.6
			Traction System (mm)		Slew Motor	Axial Piston
			Crawler (Track)	Steel	Traction Motor	Axial Piston
					Hydraulic Tank Capacity (l)	95

For more information locally

Call us direct, or contact:

Takeuchi Mfg (UK) Ltd, Lynroyle Way, Rochdale, Lancashire OL11 3EX
Tel: 01706 657 722 Fax: 01706 657 744
Email: sales@takeuchi-mfg.co.uk www.takeuchi-mfg.co.uk

Southern Depot at 20 Colthrop Business Park
Colthrop Lane, Thatcham, Newbury, Berks RG19 4NB
Tel: 01635 877 196 Fax: 01635 877 195

TAKEUCHI
Japanese for reliability

TAKEUCHI
Japanese for reliability

In accordance with our established policy of constant improvement, we reserve the right to amend these specifications at any time without notice. Photographs shown may feature non-standard equipment.

TAKEUCHI

Operator Comfort



Isolation mounted cab minimises noise levels and vibration within the operators station for added operator comfort and awareness of the excavator's operating and worksite condition.



Multi-adjustable suspension seat provides for long days of productive operation with minimal operator fatigue.

Short pitch rubber tracks provide vibration free travel even on the roughest ground condition.



Heater / air conditioner provides a comfortable operating environment in all climates.

Safety

Emergency engine shutdown / return to idle system helps protect the engine from problems due to low oil pressure or high coolant temperature.

Rear mounted work lights improve job site safety by visually alerting anyone entering the excavator's swing area.

Cast iron, wrap around protective counterweight protects the engine compartment from accidental damage when working in confined areas.

Spring-applied, hydraulically released disc type parking brakes are installed on travel slew motors for safe and reliable braking performance.



Console safety lockout levers disable travel and operating controls for safe entry and exit from the excavator.

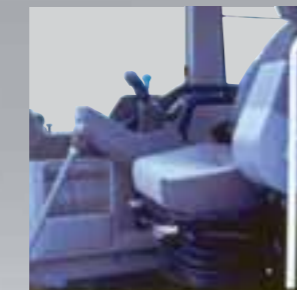

Retractable seat belt is designed for comfort, convenience and encouragement for operator use of this is important safety feature.



Side light helps illuminate dark work areas.

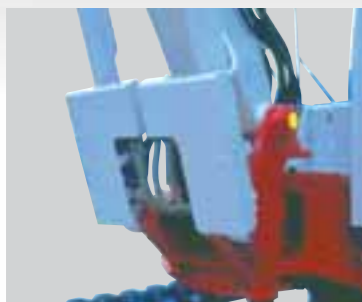

Protective routing of bucket and cylinder hoses through the boom bracket virtually eliminates hose abrasion from narrow trench walls and excavation debris. In addition, the hose routing provides an unobstructed view to the work area.

Ease of Operation



Hydraulic attachments are operated by momentary push button or proportionally controlled by the slider switch on the joystick.



One touch engine decelerator installed on the right hand joystick reduces fuel consumption when the excavator is temporarily idled.



Engine speed is easily set by feather touch button.

Two-speed travel shift-down system automatically shifts travel speed from high to low speed when ground conditions call for additional traction power, ease of operation.

Boom swing is operated by pedal.

Travel motors are equipped with shock less valves for smooth starts and stops.

Serviceability



The fuel system automatically bleeds air from fuel lines on a fuel-depleted machine saving on time, tools and unnecessary service calls.

Hydraulic test ports are conveniently located for ease of hydraulic system diagnostic testing.

Grease gun storage helps ensure that proper daily maintenance is performed.

Environmental Sensitivity



New series engine is designed to meet the most stringent worldwide exhaust emission standards and also provides significantly reduced noise levels for minimal disturbance in urban areas.



Full opening rear engine compartment allows daily machine servicing to be conveniently accomplished from ground level.

Options

TKB801 hydraulic breaker is matched to the excavator's hydraulic flow, pressure and operating capacity, enabling the excavator to efficiently perform concrete breaking and demolition work.

2nd and 3rd auxiliary hydraulic service port powers attachments that require multiple hydraulic actuation.

Quick change control pattern selector valve enables operators to quickly choose the operating pattern with which they are most familiar.

Optional long arm increases the excavator's working range.

Fuel transfer pump provides easier machine refuelling.

Immobiliser system protects the machine from theft by requiring ID coded key to start the excavator.

Auxiliary power source on top of cabin allows for easy attachment of a rotating beacon light.

Air suspension seat provides additional operator comfort through an air support system.

